



# Deer Damage Control Options

**W**hite-tailed deer are enjoyable to watch, photograph and hunt, but they can cause damage in rural as well as suburban areas of Kansas. As deer have increased in our state, they are becoming more of a problem in some areas. Hunting programs are among the most effective damage control techniques known to reduce deer damage, but they require foresight, planning and commitment by everyone. The Kansas Department of Wildlife and Parks establishes an annual deer permit quota for each deer management unit. They look at various factors in establishing these quotas, and damage problems are a primary consideration. While the Department provides the legal framework for harvest, landowners and the public hold the key to regulating local deer herds because the landowners control hunter access, and the public controls attitudes about hunting. Your input is vital.

There are many values associated with deer management. Economic values can be measured in the hundreds of millions of dollars nationwide and include such things as the sale of licenses and hunter expenditures for equipment, food and transportation. Deer also provide important aesthetic values to those who like to observe them. Despite these values, deer also have some negative connotations. Overpopulation of deer leads to a high frequency of deer/vehicle accidents, excessive agricultural crop damage including orchards and nurseries, damage to landscape plantings and even health concerns for both humans and livestock. These factors make deer damage control a difficult social and political problem as well as a biological and logistical one.

Although control methods such as repellents, scare devices, out-of-season shooting, and high tensile electric fencing can be effective, regulated hunting during the firearms deer season is a practical, effective solution to deer damage problems. To be most effective, hunting must be organized, targeted

toward certain animals and intense enough to affect deer populations.

Deer hunting programs are an important step in controlling deer damage on the farm and in suburban areas. The Kansas Department of Wildlife and Parks recognizes the importance of landowner decisions in granting or refusing hunters access, but also realizes that excessively conservative hunting programs will aggravate existing deer population problems.

## The Objective

Landowners have the opportunity to combine deer population control and hunting recreation. People who want to control deer damage must allow sufficient harvest of adult female deer. Hunting exclusively for antlered bucks does little to control the growth of a deer herd because it doesn't affect the reproductive capability of the deer population. One buck can breed many does in a single season. Harvest pressure must be on female deer if herd control is desired.

## Recruit Effective Hunters

Invite hunters who are safe, dependable and capable. Landowners typically manage hunting opportunities on their land to maximize the enjoyment of their family and friends. This need not change. Hunters can be family, friends or reliable new acquaintances. Remember, their efforts will determine the success or failure of the hunting program.

Require hunters to apply for an any-deer permit or antlerless deer permit. Although application dates vary, hunters who wish to use firearms or muzzleloaders usually apply for permits between June 15 and July 15 each year. You can help by reminding them of the application period and providing them with applications. Supplies of deer permit applications (25 or more) are available by contacting the Permits Section, Kansas Department of Wildlife and Parks, 512 SE 25th Ave., Pratt, KS 67124 (316-672-5911).

Specify that hunters with an any-deer permit harvest antlerless deer. Locate these hunters in your most promising areas. Give them the option of bagging that monster buck if it wanders by, but let them know that they should pass up ordinary antlered deer in favor of does. When possible, an adult doe should be selected from a group of does and fawns. Predictably, most hunters will readily accept the opportunity to hunt on such a farm.

Work with neighbors and the Kansas Department of Wildlife and Parks. Deer damage usually affects all farms in a community. Encourage your neighbors to allow deer hunting.

If Kansans cannot control deer populations by sport hunting, sooner or later the deer herd will be reduced artificially by paid hunters or naturally by diseases. Here are some explanations

of methods to reduce deer damage. These methods are printed here with permission and modified slightly for Kansas conditions, Scott Craven, extension wildlife specialist, University of Wisconsin, and Scott Hygnstrom, extension wildlife damage control specialist with the University of Nebraska originated the list. Most agricultural ventures involve a relatively long term commitment and substantial investment. Deer damage control options should be evaluated with that in mind. In general, larger acreage may translate to higher deer pressures but lower annual deer control costs per acre.

### Scare Devices

One of the keys to success with scare devices or repellents is to take action at the first sign of a problem. It is difficult to break a deer's behavior pattern once it is established.

Gas exploders (and possibly strobe light with sirens) set to detonate at regular intervals are the most common scare devices (Figure 1). They are effective for only 1 to 2 weeks and should be used only for temporary control.

To maximize the effectiveness of exploders, move them every few days and stagger the firing sequence. Deer quickly become accustomed to regular patterns. You can increase the noise level by raising the exploders off the ground. You can buy them for about \$200 from commercial sources.

Fireworks and gunfire can provide quick but temporary relief from deer damage. But don't rely on such tactics for an entire growing season.

A dog trained for this purpose can keep deer out of a limited area, but caring for and feeding a dog can be time consuming. Free-running dogs are not advisable unless you keep them in an enclosed area. To do this, a person might be able to use an invisible fence. This method utilizes a buried wire that emits a radio signal which triggers a shock through a receiver collar. Tests conducted in Missouri suggested using a herding breed of dog such as border collies, Australian shep-

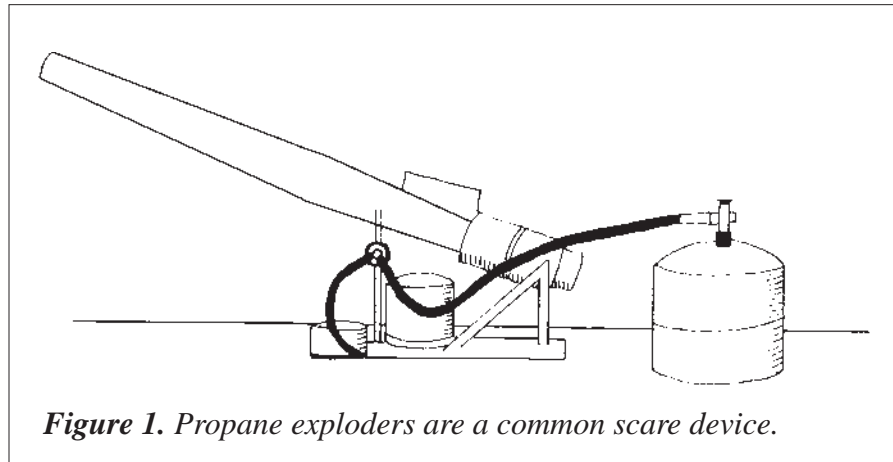

*Figure 1. Propane exploders are a common scare device.*

herds or blue heelers. To decrease the dogs attempts to leave, they should be neutered and worked for the intended purpose; keeping two working dogs in each area may also decrease the dogs attempts to leave.

### Repellents

Repellents that help prevent deer from feeding on crops are useful in damage control programs. Some materials are chemical formulations designed to repel deer; others are readily available materials that affect deer behavior.

Repellents are best for orchards, gardens and ornamental plants. The utility of repellents is limited on row crops, forages and other large-acreage crops because of high costs, limitations on use and variable results. Repellents are most valuable when integrated in a damage abatement program that includes several repellents, fencing, scare devices and herd management. It is important to anticipate deer-damage problems. Apply repellents at the first sign of damage to prevent deer from establishing a feeding pattern in your fields.

There are two kinds of repellents: contact and area. Apply contact repellents directly to plants; their taste repels deer. They are most effective on dormant trees and shrubs. During fall and winter, apply contact repellents on dry days when temperatures are above freezing. Treat young trees completely. On older trees, it's more economical to treat only terminal growth that is within reach of deer (about 6 feet

above ground level). New growth that appears after treatment is unprotected. Contact repellents may reduce the palatability of forage crops and should not be used on parts destined for human consumption.

Area repellents repel deer by odor and should be applied near plants you want to protect. Border applications of area repellents protect large acreages at a relatively low cost. Also, crops grown for human consumption may be protected because such repellents aren't applied directly to plants.

Remember, measure success with repellents by the reduction, not total elimination, of damage. Their effectiveness depends on several factors. Rainfall dissipates some repellents, so you may need to apply them again after a rain. Some do not weather well, even with no rainfall. Hunger and the availability of other, more palatable deer food dictates the effectiveness of repellents. When deer are very hungry, they may ignore both taste and odor repellents.

When using repellents, don't overlook new preparations or imaginative ways to use old ones. The following discussion of common repellents may be incomplete, but it indicates the wide range of repellents available. The repellents are grouped by active ingredient and include a brief description of use, application rates and costs. Product labels provide all necessary information on use and must be followed not only as a legal requirement but also to achieve maximum success. The active

ingredients are shown in parentheses beneath the trade names. Cost estimates are provided for comparative purposes. "Home remedies" such as blood meal, feather meal, cat feces, mothballs, creosote and rotten eggs have been used with mixed success.

#### **Deer Away® Big Game Repellent (37 percent putrescent egg solid)**

This contact (odor/taste) repellent has been used extensively in western conifer plantations and reported to be 85 to 100 percent effective in field studies. It is registered for use on fruit trees prior to flowering and ornamental and Christmas trees.

Apply it to all susceptible new growth and leaders. Applications weather well and are effective for two to six months. One gallon of liquid or 1 pound of powder costs about \$32 and covers 400 3-inch saplings or 75 4-foot evergreen shrubs.

#### **Hinder® (15 percent ammonium soaps of higher fatty acids)**

This area repellent is one of the few registered for use on edible crops. You can apply it directly to vegetable and field crops, forages, ornamentals and fruit trees. Its effectiveness is usually limited to two to four weeks but varies because of weather and application technique. Reapplication may be necessary after heavy rains. For fields less than 30 acres, you can treat the entire field; for fields greater than 30 acres, apply an 8- to 15-foot strip around the perimeter of the field. Apply at temperatures above 32°F. Four gallons of liquid cost about \$80, and when mixed with 100 gallons of water will cover one acre. Hinder is compatible for use with most pesticides.

#### **Thiram (7 to 42 percent tetramethylthiuram disulfide)**

Thiram, a fungicide which acts as a contact (taste) deer repellent, is sold under several trade names: Bonide® Rabbit-Deer Repellent®, Nott's Chew-Nott®, Gustafson 42-S®, and Wilbur-Ellis Scram 42-S® and others. It is most often used on dormant trees and shrubs. A liquid formulation is sprayed or painted on individual

trees. Although thiram itself does not weather well, adhesives such as Latex 202-A® or Vapor Gard® can be added to the mixture to increase its resistance to weathering. Thiram-based repellents also protect trees against rabbit and mouse damage. Two gallons of 42 percent thiram cost about \$50 and when mixed with 100 gallons of water will cover 1 acre.

#### **Miller's Hot Sauce Animal Repellent® (2.5 percent capsaicin)**

This contact (taste) repellent is registered for use on ornamental, Christmas and fruit trees. Apply it with a backpack or trigger sprayer to all susceptible new growth, such as leaders and young leaves. Do not apply to fruit-bearing plants after fruit set. Vegetable crops also can be protected if sprayed prior to the development of edible parts. Weatherability can be improved by adding an antitranspirant such as Wilt-Pruf® or Vapor Gard®. Hot Sauce® and Vapor Gard® cost about \$80 and \$30 per gallon respectively. Eight ounces of Hot Sauce® and 2 quarts of antitranspirant mixed with 100 gallons of water will cover 1 acre.

#### **Tankage (putrefied meat scraps)**

Tankage is a slaughterhouse by-product traditionally used as a deer repellent in orchards. It repels deer by smell, which is readily apparent. To prepare containers for tankage, remove the tops from aluminum pop cans, puncture the sides in the middle of the cans to allow for drainage and attach the cans to the ends of 4-foot stakes. Drive the stakes into the ground, 1 foot from every tree you want to protect or at 6-foot intervals around the perimeter of a block. Place 1 cup of tankage in each can. You can use cloth bags instead of cans. You may have to replace the containers periodically because fox or other animals sometimes pull them down. A 50-pound bag costs \$20 and is enough to make 300 bags, which will cover 2 acres.

#### **Ro-pel® (benzyl diethyl [(2,6 xylyl-carbomoyl) methyl] ammonium saccharide (0.065 percent) thymol (0.035 percent))**

Ro-pel® repels deer with its extremely bitter taste. Apply Ro-pel once each year to new growth. It is not recommended for use on edible crops. Spray at full strength on nursery and Christmas trees, ornamentals and flowers. One gallon costs \$50 and covers about 1 acre of 8- to 10-foot trees.

#### **Tree Guard® Deer Repellent (denatonium benzoate)**

Tree Guard® contains Bitrex—one of the most bitter substances known. Combined with a detection agent, deer are conditioned to identify treated plants and leave them alone. The plant is bonded to plant surfaces with a latex formulation. This formulation weathers well and is applied about once per month to flowers and ornamentals and once or twice per year on evergreens. New growth would have to be treated to be protected. The product is applied with a backpack, pump up or hydraulic sprayer and does not discolor leaves. It is not suited for food crops. One gallon costs about \$170 and will treat about 1,000 seedlings.

#### **Bar Soap**

Several recent studies and numerous testimonials have shown that ordinary bars of soap suspended from tree branches can reduce deer damage. Drill a hole in each bar and suspend with a twist tie or string. Each bar appears to protect a radius of about 1 yard. Any inexpensive brand of bar soap will work.

#### **Deer Fencing**

Where deer are abundant or crops are particularly valuable, fencing may be the only way to effectively minimize deer damage. Several fencing designs are available to meet specific needs. Temporary electrified fences are simple, inexpensive fences that are useful in protecting garden and field crops during snow-free periods. Deer are attracted to these fences by their appearance or smell, and are lured into contacting the fence with their noses.



This causes an effective shock that trains them to avoid the fenced area.

Permanent, high-tensile, electric fences provide year-round protection from deer and are best suited to high-valued specialty or orchard crops. The electric shocking power and unique fence designs present both psychological and physical barriers to deer. Permanent woven-wire fences provide the ultimate deer barrier. They require little maintenance but are expensive to build. Fencing in general is expensive. You should consider several points before constructing a fence:

1. History of the area. Assemble information on past claims, field histories, deer numbers and movements to help you decide on an abatement method.
2. Deer pressure. This reflects both the number of deer and their level of dependence on agricultural crops. If deer pressure in your area is high, you probably need fences.
3. Crop value. Crops with high market values and perennial crops where damage affects future yields and growth often need the protection fencing can provide.
4. Field size. In general, fencing is practical for areas of 40 acres or less. However, the cost per acre for fencing usually decreases as acreage increases.
5. Cost-benefit analysis. To determine the cost effectiveness of fencing and the type of fence to install, weigh the value of the crop to be protected against the acreage involved, the cost of fence construction and maintenance, and the fence's life expectancy.
6. Rapidly changing technology. If you intend to build a fence yourself, supplement the following directions by consulting the detailed fencing manuals that are available from most fencing manufacturers.

### Temporary Electric Fencing

Temporary electric fences provide inexpensive protection for many crops during periods without snow. They are easy to construct, do not require rigid corners, and use readily available materials. Install fences at the first sign of damage to prevent deer from estab-

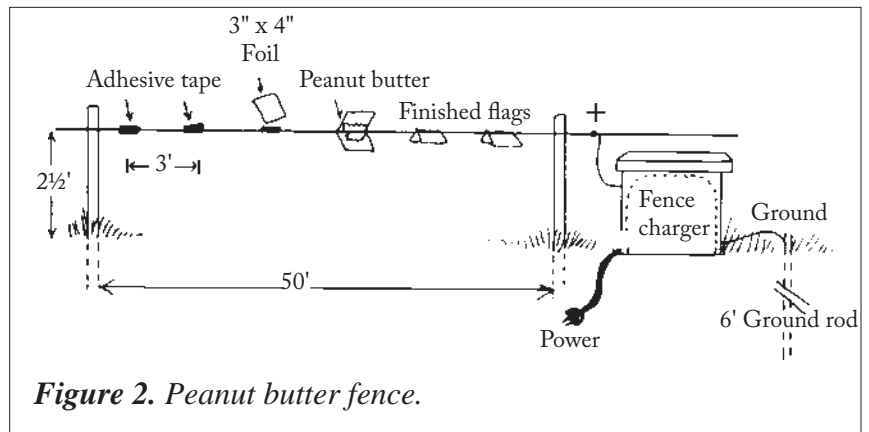

**Figure 2.** Peanut butter fence.

lishing feeding patterns in your crops. Such fences require weekly inspection and maintenance. Success can be improved by tightly fastening the wire to the insulator rather than using a clip.

### Peanut Butter Fence

The peanut butter fence is effective for moderately sized truck gardens, nurseries, orchards and field crops up to 40 acres that are subject to moderate deer pressure. Deer are attracted by the peanut butter and encouraged to make nose-to-fence contact. After being shocked, deer learn to avoid fenced areas. Cost, excluding labor, is about 10 cents per linear foot.

To build a peanut butter fence (Figure 2), follow these steps:

1. Install wooden corner posts.
2. String one strand of 17-gauge, smooth wire around the corners and apply light tension.
3. Set 4-foot fiberglass rods along the wire at 60-foot intervals.
4. Attach the wire to insulators on the rods at 2 1/2 feet above ground level and apply 50 pounds of tension.
5. Attach 3- x 4-inch foil strips to the wire at 3-foot intervals, using 1- x 2-inch strips of cloth adhesive tape.
6. Apply a 1:1 mixture of peanut butter and vegetable oil to the adhesive tape strips and fold the foil over the tape.
7. Connect the wire to the positive (+) post of a well-grounded fence charger.
8. For fields larger than 1 acre, it is more practical to apply the peanut butter mixture directly to the wire.

You can make a simple applicator by mounting a free-spinning, 4-inch pulley on a shaft inside a plastic ice cream pail. Fill the pail with a peanut butter-vegetable oil mixture with the consistency of very thick paint. Coat the entire wire with peanut butter by drawing it along the pulley. Apply peanut butter once a month. Attach foil flags to the fence near runways or areas of high deer pressure to make the fence more attractive.

Check the fence weekly for damage by deer and grounding by vegetation.

### Visible Grazing Systems (VGS) Fence

The VGS material is very strong and portable. Stainless steel conductors are intertwined within polyethylene ribbon or polywire. Baygard, Galagher, Stafix, Pel and Speedrite are some of the companies that have VGS material. You can use this system to protect up to 40 acres of vegetable and field crops under moderate deer pressure. Deer receive shocks through nose-to-fence contact and they learn to avoid fenced areas. Cost, excluding labor, is about 15 cents per linear foot. Effectiveness can be improved by coating the polywire or tape with a mixture of peanut oil and peanut butter.

To build a VGS fence (Figure 3), follow these steps:

1. Drive 5/8-inch round fiberglass posts 2 feet into the ground at the corners.
2. String two strands of VGS around the corners and apply light tension (one strand 3-foot high can be used).

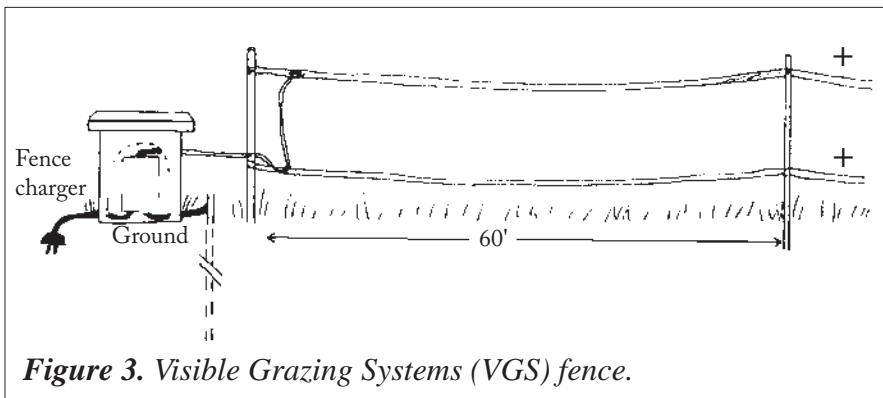

**Figure 3.** Visible Grazing Systems (VGS) fence.

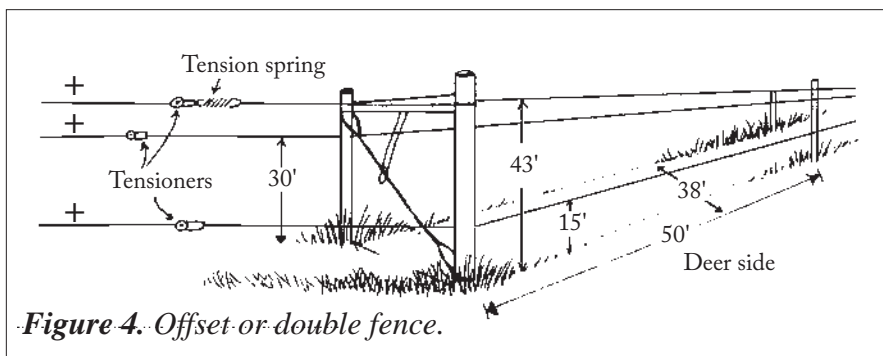

**Figure 4.** Offset or double fence.

3. Follow manufacturer recommendations for splicing. Use square knots or half-hitches to secure the VGS to corner posts.
4. Set 4-foot fiberglass rods along the wires at 60-foot intervals.
5. Attach the two strands of VGS to insulators on the rods at 1- and 3-feet above-ground level and apply 50 pounds of tension.
6. Connect the VGS to the positive (+) post of a well grounded fence charger. To maintain the fence, check it weekly for damage by deer and grounding by vegetation.

### Permanent High-Tensile Electric Fencing

High-tensile fencing can provide year-round protection from deer damage. Many designs are available to fit specific needs. All require strict adherence to construction guidelines concerning rigid corner assemblies and fence configurations. Frequent inspection and maintenance are necessary. High-tensile fences have a 20- to 30-year life expectancy.

### Offset or Double Fence

This fence is mostly for gardens, truck farms or nurseries up to about 40 acres that experience moderate deer pressure. Deer are repelled by the shock

and the fence's three-dimensional nature. You can add wires if deer pressure increases. Cost, excluding labor, is about 35 cents per linear foot.

To build an offset or double fence (Figure 4), follow these steps:

For the outside fence:

1. Install swing corner assemblies where necessary (see the section on rigid brace assemblies).
2. String a 12½-gauge high-tensile wire around the outside of the swing corner assemblies and apply light tension.
3. Set 5-foot line posts along the wire at 40- to 60-foot intervals.
4. Attach the wire to insulators on the line posts, 15 inches above ground level and apply 150 to 250 pounds of tension.
5. String a second wire at 43 inches and apply 150 to 250 pounds of tension.

For the inside fence:

6. String a wire around the inside of the swing corner assemblies and apply light tension.
7. Set 5-foot line posts along the wire at 40- to 60-foot intervals.

8. Attach the wire to insulators on the line posts at 30 inches above ground level.
9. Attach all wires to the positive (+) post of a well-grounded, low-impedance fence charger.
10. Clear and maintain a 6- to 12-foot open area outside the fence so deer can see it.

Maintenance includes weekly inspection and voltage checks.

### Vertical Deer Fence

Vertical fences are effective at protecting large truck gardens, orchards and other fields from moderate to high deer pressures. Because of the prescribed wire spacing, deer try to go through the fence and are effectively shocked. Vertical fences use less ground space than three-dimensional fences, but are probably less effective at keeping deer from jumping over fences. There is a wide variety of fence materials and specific designs you can use. It is recommended that you employ a local fence contractor. Cost, excluding labor, ranges from \$0.75 to \$1.50 per linear foot.

To build a seven-wire vertical deer fence (Figure 5), follow these steps.

1. Install rigid corner assemblies where necessary.
2. String a 12½-gauge high-tensile wire around the corner assemblies and apply light tension.
3. Set 8-foot line posts along the wire at 33-foot intervals.
4. Attach the wire to insulators at 8 inches above ground level and apply 150 to 250 pounds of tension.
5. Attach the remaining wires to insulators at 16, 26, 36, 48, 60, and 72 inches above ground level and apply 150 to 250 pounds of tension.
6. Connect the first, third and fifth wires from the top, and the bottom wire to the positive (+) post of a well grounded, low-impedance fence charger.
7. Connect the second, fourth and sixth wires directly to ground. The top wire should be negative for lightning protection and the bottom wire should be "hot" to prevent deer from crawling under the fence.

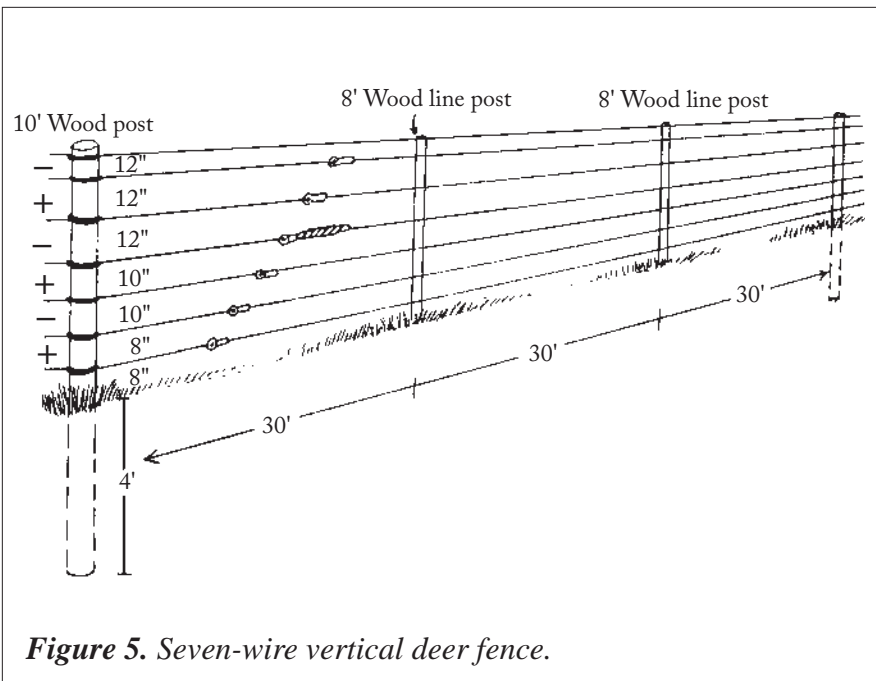

**Figure 5.** Seven-wire vertical deer fence.

8. Clear and maintain a 6- to 12-foot open area outside the fence so deer can see it.

Maintenance includes weekly fence inspection and voltage checks.

#### Slanted Seven-Wire Deer Fence

This fence is used where high deer pressures threaten moderate to large-size orchards, nurseries and other high value crops. It presents a physical and psychological barrier to deer because of its electric shock and three-dimensional nature. Cost, excluding labor, is \$1.50 to \$2 per linear foot.

To build a slanted seven-wire deer fence (Figure 6), follow these steps:

1. Set rigid, swing corner assemblies where necessary.
2. String 12½-gauge high-tensile wire around the corner assemblies and apply light tension.
3. Set angle braces along the wire at 90-foot intervals.
4. Attach a wire at the 10-inch position and apply 150 pounds of tension.
5. Attach the remaining wires at 12-inch intervals and apply 150 pounds of tension.
6. Place fence battens at 30-foot intervals.

7. Connect the top, third, fifth and bottom wires to the positive (+) post of a well-grounded, low-impedance fence charger.
8. Connect the second, fourth and sixth wires directly to ground.
9. Clear and maintain a 6- to 12-foot area outside the fence so deer can see the fence.

Maintenance includes weekly inspection and voltage checks.

#### Permanent Woven-Wire Fencing

Woven-wire fences are used for year-round protection of high-value crops subject to high deer pressures. These fences are expensive, difficult to construct, but easy to maintain. Before high tensile electric fencing, woven-wire fences were used most often to protect orchards or nurseries where the high crop value, perennial nature of damage, acreage, and 20-year life span of the fence justified its initial costs. Cost, excluding labor, is \$2 to \$4 per linear foot. The high cost has resulted in reduced use of woven wire fences.

To build a deer-proof woven-wire fence (Figure 7) follow these steps:

1. Set rigid corner assemblies where necessary.
2. String a light wire between two corners and apply light tension.

3. Set 16-foot posts along the wire at 40-foot intervals, to a depth of 4 to 6 feet.
4. At ground level, attach a roll of 4-foot woven wire to each of the two corners and roll them out to the center of the run.
5. Attach fence strainers to the free ends of the two rolls, apply 50 pounds of tension and splice the roll-ends together.
6. For the 4- to 8-foot span, start at the 4-foot level and repeat steps 4 and 5.
7. Attach the 0- to 4-foot and 4- to 8-foot spans together with hog rings.
8. Repeat steps 3 through 7 for the remaining sides of the fence.
9. Attach two strands of high-tensile smooth wire to the top of the fence to raise the height of the entire fence to 9 to 10 feet.

Minimal maintenance is required.

Inspect for locations where deer can crawl under the fence.

#### Fencing Tips

Do not buy cheap materials to reduce costs. This will only reduce the effectiveness and life span of the fence. Recommended materials include:

- Fiberglass or treated wood posts.
- High quality galvanized wire and steel components. For high-tensile (HT) fences, use 11 to 14 gauge wire (minimum tensile strength of 200,000 pounds and a minimum breaking strength of 1,800 pounds), tension springs, and in-line tensioners.
- Compression sleeves for splicing wires and making electrical connections.
- Lightning arrestors or newer lightning diverters to protect chargers.
- High-quality fence chargers. Chargers must be Underwriters Laboratories (UL) approved. Approval by the Canadian Standards Association (CSA) is equally acceptable. Kansas wildlife experts recommend 110-volt chargers. Six- and 12-volt chargers require battery recharging every two

to four weeks. For high-tensile fences, use high-voltage, low-impedance chargers only (3,000 to 5,000 volts and current pulse of at least one one-thousandth second).

- There is no universal gate design because of the many different fence types. Gates should be electrified, well insulated and practical for the type of farming operation. Gates range from single strands of electrified wire with gate handles, to electrified panel or tubular gates.
- The wiring system in a positive-negative fence is especially useful under dry or frozen ground conditions. A fence with all positive (hot) wires may be advantageous under general crop and soil moisture conditions. Consult an expert for the best choice for your needs.

### Fence Construction

Fences must be properly constructed; do not deviate from guidelines.

- Prepare fencelines before construction. It is easier and less expensive to install and maintain fences on clear, level runs. Mini-

mize corners to increase strength and reduce cost.

- Ensure that the electrical system is well grounded at the fence charger and every half mile of fenceline. To ground high-tensile fences, drive four grounding rods 5 to 6 feet deep and 6 feet apart. Con-

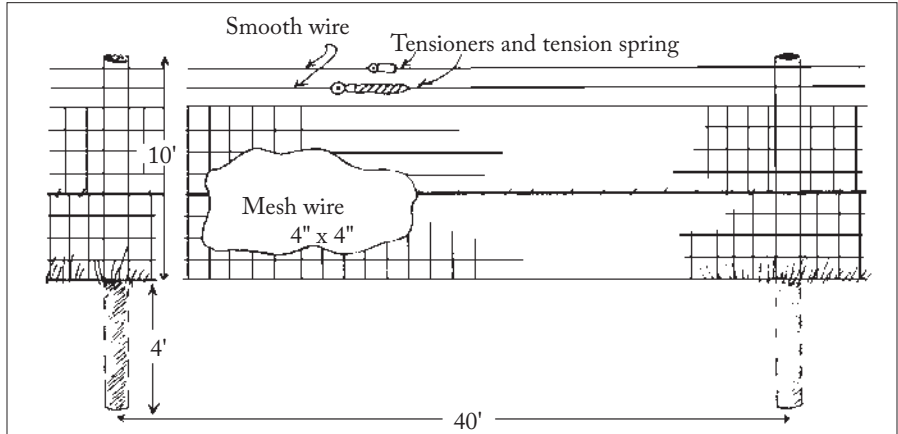

Figure 7. Deer-proof woven wire fence.

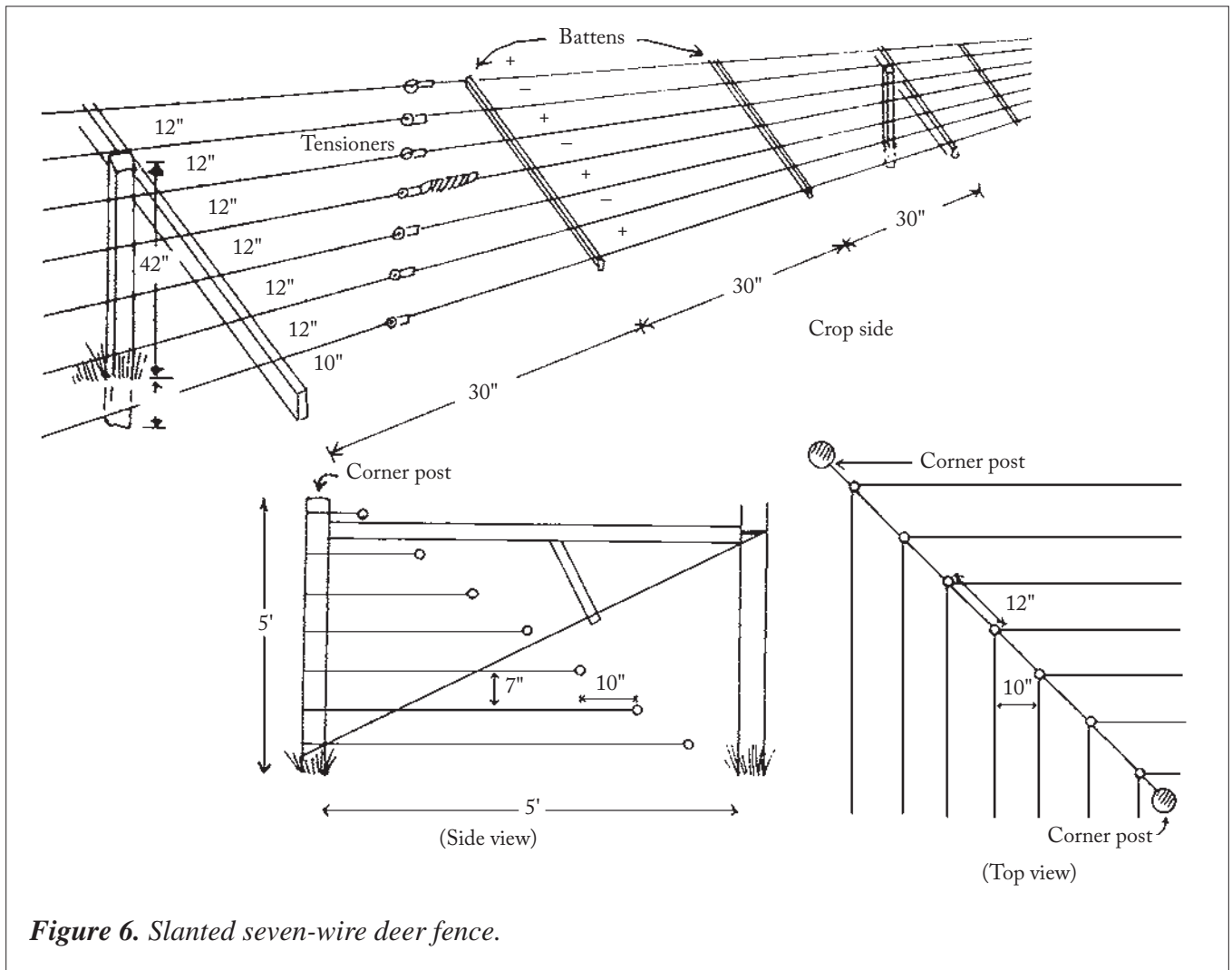

Figure 6. Slanted seven-wire deer fence.



nect the ground post of the fence charger and the negative (-) wires of the fence to the grounding system.

- Install the grounding systems and fence charger before fence construction. When you aren't working on the fence, energize completed parts to gain early protection.
- Rigid brace assemblies—corners, ends and gates—make up the backbone of all high-tensile fence systems. They must be entirely rigid, constructed of the best materials, and conform strictly to design guidelines. The single-span brace assembly is the basis of all high-tensile strainer assemblies, regardless of location in the fence or fence design. This basic design is then modified to create double-H braces, swing corners and gate ends.
- Allow wires to slide freely through insulators on fence posts. Fence flexibility is necessary to endure frequent temperature changes, deer hits and obstructions.
- Identify an electric fence with warning signs that are affixed to it at 300-foot intervals or less.

## Maintenance

Regular inspection and maintenance are necessary to ensure the effective operation and longevity of most fences.

- Control vegetation near fences by mowing or applying herbicides to avoid excessive fence grounding by weeds.
- On slopes or highly erodible soils, maintain a good sod cover beneath fences to avoid fenceline erosion.
- Always keep the fence charger on. Check the fence voltage weekly with a voltmeter. Maintain at least 3,000 volts at the furthest distance from the fence charger. Disconnect the lower wires if they are covered by snow.
- In late fall or early summer, adjust the fence tension (150 to 250 pounds) for high-tensile fences.

## Out-of-Season Shooting Permits

Occasionally, deer damage to private property is not anticipated and it occurs with sufficient severity to cause substantial economic loss to the landowner. The landowner may be unsuccessful in deterring or excluding deer from the problem location. The landowner may not be able to wait until regular deer hunting season affords them an opportunity to reduce the deer population. This circumstance may justify a special control permit.

Damage control permits are available from the Kansas Department of Wildlife and Parks to address localized hot-spots of deer damage. These permits allow landowners to kill deer outside the normal deer hunting seasons. They also allow the landowner to possess and use the carcass of the deer they kill during the control operation. Damage control permits are issued on a site-by-site basis after an inspection of the damage by one of the department's district wildlife biologists. Each permit is issued for a specific number and type of deer. For more information on deer damage control permits contact your local district wildlife biologist or the operations office, 512 SE 25th Avenue, Pratt, KS 67124, (316) 672-5911.

For further information contact Wildlife Damage Control, Call Hall, Kansas State University, Manhattan, Kansas 66506-1600, (785) 532-5734 or Kansas Department of Wildlife and Parks staff.

## Sources of Supply

Most nurseries, garden centers, and farm co-ops sell commercial repellents and fencing materials. Locating other materials like tankage or inexpensive bar soap requires some ingenuity.

Several companies and the products they supply include:

### Exploders

Margo Supplies Ltd., Rt. 6, Site 8, Box 2, Calgary, Alberta, Canada T2M 4L5 (403) 285-9731.

Reed-Joseph International Co., P.O. Box 894, Greenville, MS 38702 (800) 647-5554.

### Repellents

(Deer-Away) IntAgra, Inc., 8500 Pillsbury Ave. S. Minneapolis, MN 55420 (612) 881-5535.

(Hinder) Pace International, Leffingwell Div., 111 S. Berry St., P.O. Box 1880, Brea, CA 98621 (714) 529-3973.

(Thiram) Wilbur-Ellis Co., P.O. Box 8838, Portland, OR 97209 (800) 937-3446.

(Thiram) Bonide Chemical Co., Inc., 2 Wurtz Ave., Yorkville, NY 13495 (315) 736-8231.

(Thiram) Nott Manufacturing Co., Pleasant Valley, NY 12569 (914) 635-3243.

(Thiram) Gustafson, Inc., 17400 Dallas N. Pkwy., Suite 220, Dallas, TX 75252 (800) 527-4781.

(Tree Guard) Nortech Forest Technologies, 7600 West 27th St. Suite B-11, St. Louis Park, MN 55426 (612) 922-2520

(Hot Sauce Animal Repellent) Miller Chemical and Fertilizer Corporation, P.O. Box 333, Radio Road, Hanover, PA 17331 (800) 233-2040.



(Ro-pel) Burlington Scientific Corp.,  
91 Carolyn Blvd., Farmingdale, NY  
11735-1527 (516) 694-9000.

(Bar soap and Tankage) Lakeshore  
Enterprises, 2804 Benzie Hwy., Ben-  
zonia, MI 49616 (616) 882-9601.

**Fences**

(HT and VGS fencing) Grassland  
Supply Ltd., Rt. 3, Box 6, Council  
Grove, KS 66846 (800) 527-5487.

(HT, VGS and woven wire fencing)  
K Fence Systems, Rt. 1, Box 20, Zum-  
bro Falls, MN 55991  
(507) 753-2943.

(HT and VGS fencing) Live Wire  
Products, Inc., 1127 "E" Street, Marys-  
ville, CA 95901  
(916) 743-9045.

(HT and VGS fencing) McBee Agri  
Supply, Rt. 1, Box 121 Sturgeon, MO.  
65284 (314) 696-2517.

(VGS fencing) Margo Supplies Ltd.,  
Site 20, Box 11, Rt. 6, Calgary, Alberta,  
T2M 4L5 (403) 285-9731.

(HT, VGS woven wire fencing) Pre-  
mier Fence Systems, Box 89, Washing-  
ton, IA 52353,  
(319) 653-6631/6632/6634.

(HT, VGS and woven wire fencing)  
Twin Mountain Fence Co., P.O.  
Box 2240, San Angelo, TX 76902,  
(800) 527-0990.

(HT and VGS fencing)  
Techfence Advanced Farm Systems,  
Inc., Rt. 1, Box 364, Bradford, ME  
04410 (207)327-1237; or, Rt. 1, Box  
45, Elroy, WI 53929, (608) 462-5771.

---

**Notes:**



**Information Sources  
for this Publication**

*Prevention and Control of Wildlife Damage*, 1994, Hygnstrom, S.E., R.M. Timm, G.E. Larson, ed., Univ. of Nebraska Cooperative Extension, Lincoln, NE, USDA-APHIS-ADC, Great Plains Agricultural Council.

*Deer Damage Control in New York Agriculture*, 1983, by J.B. McAnninch, M.R. Ellingwood and R.J. Winchcombe, New York Department of Agriculture and Markets, State Campus, Albany, NY.

*Control of Wildlife Damage in Orchards and Vineyards*, 1977, by J.W. Caslick and D.J. Decker, Information Bulletin 10, Dept.

Nat. Res., N.Y. State Coll. Agr. and Life Sci., Cornell Univ., Ithaca, N.Y.

*How to Build Fences with U.S.S. MAX-TEN 200*, United States Steel, Pittsburg, PA.

*High-Tensile Wire Fencing*, 1981, by A.W. Selders, J.B. McAnninch and R.J. Winchcombe, Northeast Regional Agricultural Engineering Serv. Bull. 11, Cornell Univ., Ithaca, NY.

*Building an Electric Anti-Predator Fence*, 1983, by D.S. de Calesta, Pacific Northwest Extension Publication 225, Oregon State Univ. Extension Service, Corvallis, OR.

*Low-Cost Electric Deer Fence for Many Small Acreage Applications*, 1993, by J. Kays, Cooperative Extension Service, University of Maryland System, Keedysville, MD.

Illustrations from *Controlling Deer Damage in Wisconsin*, Scott Craven and Scott Hygnstrom, University of Wisconsin-Extension.

**Charles D. Lee  
Extension Specialist, Wildlife**

Brand names appearing in this publication are for product identification purposes only. No endorsement is intended, nor is criticism implied of similar products not mentioned.

Publications from Kansas State University are available on the World Wide Web at: <http://www.oznet.ksu.edu>

Contents of this publication may be freely reproduced for educational purposes. All other rights reserved. In each case, credit Charles D. Lee, *Deer Damage Control Options*, Kansas State University, January 1998.

**Kansas State University Agricultural Experiment Station and Cooperative Extension Service**

C-728

January 1998

It is the policy of Kansas State University Agricultural Experiment Station and Cooperative Extension Service that all persons shall have equal opportunity and access to its educational programs, services, activities, and materials without regard to race, color, religion, national origin, sex, age or disability. Kansas State University is an equal opportunity organization. Issued in furtherance of Cooperative Extension Work, Acts of May 8 and June 30, 1914, as amended. Kansas State University, County Extension Councils, Extension Districts, and United States Department of Agriculture Cooperating, Marc A. Johnson, Director.

File code: Wildlife—3-1